

System-level Gesture Photoelectric Switch

Introduction

System-level gesture photoelectric switch is controlled by microprocessor (MCU). It can meet the application requirements and use scenarios for different customers. This product integrates infrared receiver, transmitter, MCU, signal processing unit and output control unit. It has strong anti-photoelectric interference ability, stable and reliable performance and small size.

This product is suitable for various household appliances, such as multi-gesture logic function control, lighting fixture switch and brightness control, display backlight control, toys, intelligent trash cans, object motion direction recognition and other consumer products and other induction control scenes.

The dimensions of this product can be customized according to customer requirements.

Working Principle

The infrared transmitter transmits two coded infrared signals. When a hand or an object moves in the detection area, the reflected two infrared signals are received and processed by the receiving module. After judging the time sequence of the reflected two signals, the MCU identifies gestures and the moving direction of the moving object, and then outputs low-level signals with different pulse widths to realize a variety of logic output control signals. The signal line is connected with the MCU IO port or other control interfaces of the customer product. By detecting the low-level pulse width of the signal line, peripherals are realized.

Functional Block Diagram

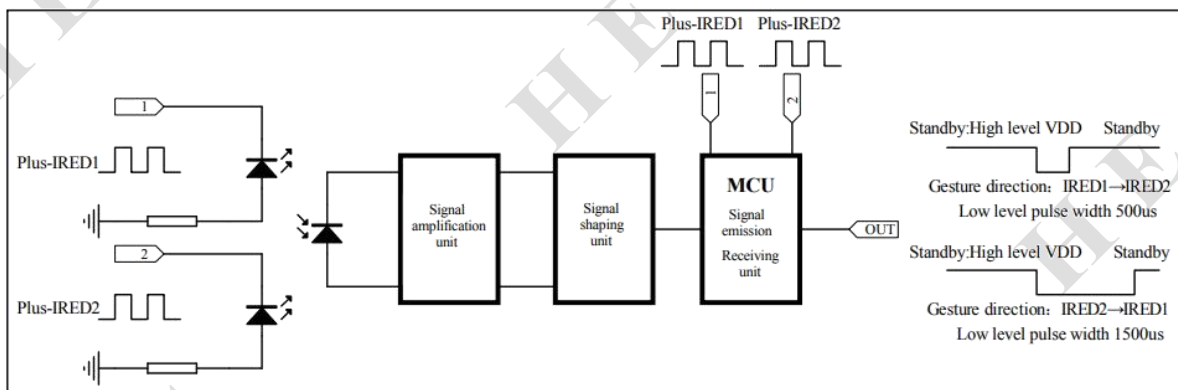

Model Naming Rules

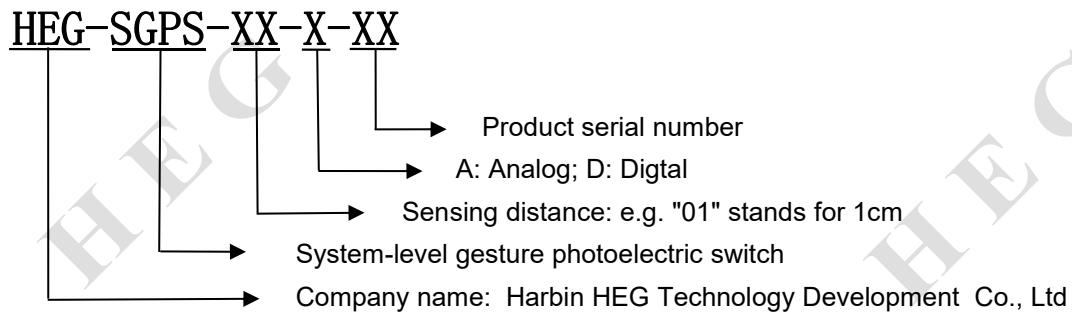

Product Features

- 1、Volume: 14mm×8.5mm×3.75mm;
- 2、Sensing distance: 2-20cm,High sensitivity; See test method for details;
- 3、Light immunity: strong immunity to ambient light.

Product Appearance Picture



HEG-SGPS-XX-D-01

Main Technical Parameters of Products

Main Parameter	Numerical Value	Unit	Remarks
Operating Voltage (DC)	3.0-5.5	V	Recommend:VDD=3.3V-5.0V
Signal Output Mode	Low level pulse signal	/	On standby: when pin signal is triggered by high level VDD: when IRED1→IRED2, it is input Output 500us low-level pulse signal; Output when IRED2→IRED 1500us low level pulse signal; (customizable)
Output Drive Current	≤10.0	mA	Test condition:VDD=3.3V
Outline Dimension	L*W*H 14*8.5*3.75	mm	Customizable
Port	8Pin	mm	8 Patch pin

Inductive Distance	d=2-20	cm	Test condition:VDD=3.3V; See below for test methods; When transparent glass or infrared transparent panel is set in front of the sensor, the distance between the sample and the panel ≤ 1mm; (customizable)
Gesture Swing Amplitude	≥20	cm	Test conditions: at the induction distance of 20cm

Test Method

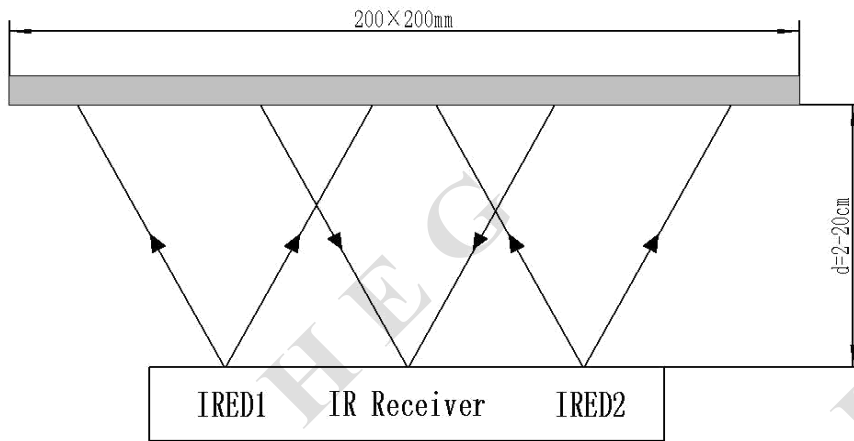

HEG-SGPS-XX-D-01

Instructions for Product Use

OUT 1

NC 2

VDD 3

NC 4

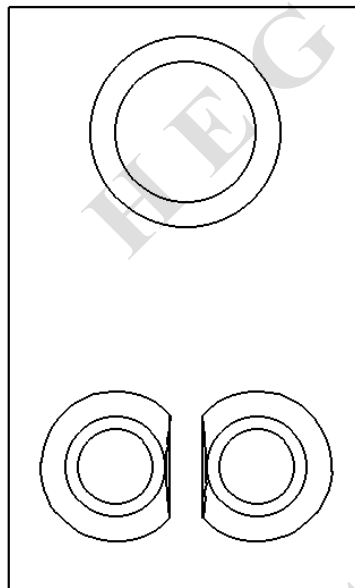

8 GND

7 NC

6 NC

5 VDD

Pin Number	Pin Name	Description
1	OUT	Signal output
2	NC	NC
3	VDD	Dc power supply positive terminal
4	NC	NC
5	VDD	Dc power supply positive terminal
6	NC	NC
7	NC	NC
8	GND	Dc power supply negative terminal

Overall Dimension Drawing (unit: mm)

1、Unit : mm ;

2、Dimensional tolerance : $\pm 0.05\text{mm}$;

