

SURFACE MOUNT CHIP LED LAMPS

DATA SHEET

MODEL NO: GT3014-7W84DY

REV. : 1.0

DATE : 01-Apr.-2009

Features

- . P-LCC-2 package.
- . White package.
- . Optical indicator.
- . Colorless clear window.
- . Pb-free.
- . Wide viewing angle.
- . Computable with automatic placement equipment.
- . Suitable for vapor-phase reflow, Infrared reflow and wave solder processes.
- . The product itself will remain within RoHS compliant version



Descriptions

The GT3014 series is available in soft orange, green, blue, and yellow. Due to the package design, the LED has wide viewing angle and optimized light coupling by inter reflector. This feature makes ideal for light pipe application. The low current requirement makes this device ideal for portable equipment or any other application where power is at a premium.

Applications

- . Optical indicator
- . indicator and backlighting in telephone and fax.
- . Flat backlight for LCD, switch and symbol.
- . Light pipe application.
- . General use.

Device Selection Guide

Material	Resin (mold)	Resin Color	Emitted Color
InGaN	Epoxy	Yellow Diffused	White

Package Dimension

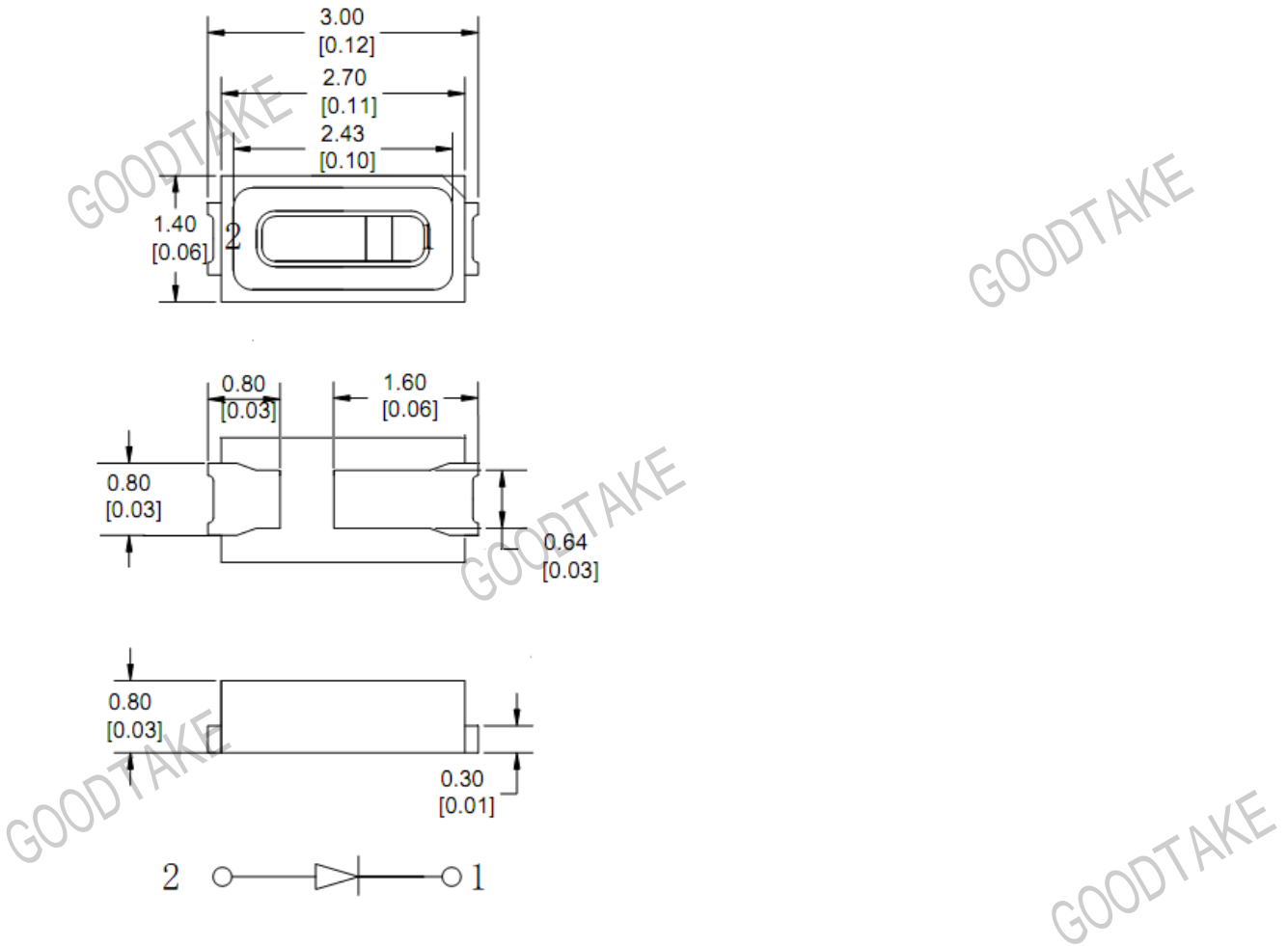

Note: The tolerances unless mentioned is $\pm 0.1\text{mm}$, Unit = mm

Absolute Maximum Rating (Ta=25°C)

Item	Symbol	Condition	Absolute Maximum Rating	Unit
Forward Current	I _F		40	mA
Power Dissipation	P _D		120	mW
Operating Temperature	T _{opr}		-40~+85	°C
Storage Temperature	T _{stg}		-55~+100	°C
Electrostatic Discharge	ESD		1000 (HBM)	V

Electrical and Optical Characteristics at (Ta=25°C)

Item	Symbol	Condition	Min	Typ	Max	Unit
Forward Voltage	V _F	I _F =30mA	2.8	--	3.6	V
50%Power angle	2θ _{1/2}		--	120	--	Deg
Luminous Flux	Φ _v		3500	--	4300	Mcd
Chromaticity Coordinates	CIE-X		0.3069	--	0.3584	--
	CIE-Y	0.3147	--	0.4120	--	
Reverse Voltage	V _R	I _R =5mA		0.9	1.2	V

Luminous Flux (lm at 30mA)

Rank	Min (mcd)	Max (mcd)
H	3500	3700
I	3700	3900
J	3900	4100
K	4100	4300

*Measurement Uncertainty of Luminous Intensity: ±10%.

Forward Voltage Combination (V at 30mA)

Rank T	0	1	2	3
Forward Voltage	2.8~2.9	2.9~3.0	3.0~3.1	3.1~3.2
Rank R	0	1	2	3
Forward Voltage	3.2~3.3	3.3~3.4	3.4~3.5	3.5~3.6

*Measurement Uncertainty of Forward Voltage: ±0.1V.

Color Combination (IF= 30mA)

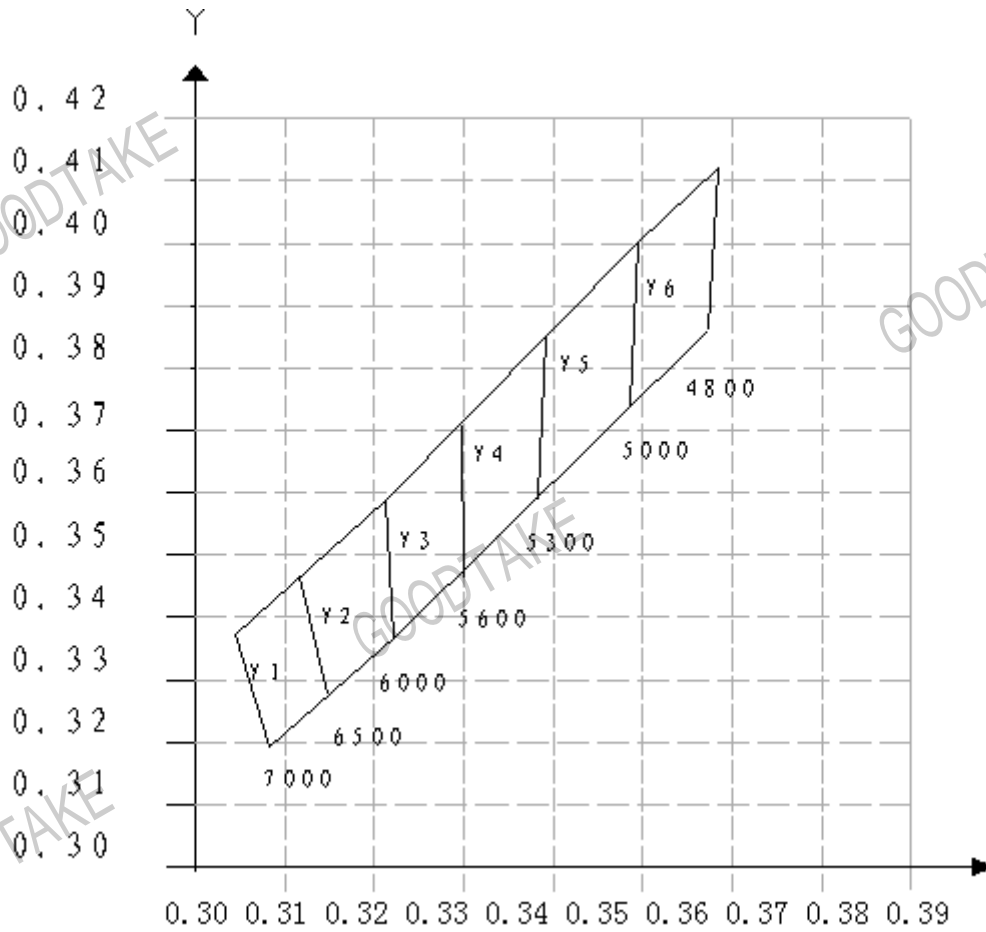

Color Ranks(IF=30mA,Ta=25°C)

Color Ranks		CIE				CCT
Y1	X	0.3069	0.3092	0.3152	0.3131	6500-7000K
	Y	0.3266	0.3147	0.3236	0.3372	
Y2	X	0.3152	0.3131	0.3224	0.3214	6000-6500K
	Y	0.3236	0.3372	0.3343	0.3518	
Y3	X	0.3224	0.3214	0.3300	0.3297	5600-6000K
	Y	0.3343	0.3518	0.3456	0.3661	
Y4	X	0.3300	0.3297	0.3381	0.3390	5300-5600K
	Y	0.3456	0.3661	0.3577	0.3821	
Y5	X	0.3381	0.3390	0.3485	0.3495	5000-5300K
	Y	0.3577	0.3821	0.3731	0.4003	
Y6	X	0.3485	0.3495	0.3573	0.3584	4800-5000K
	Y	0.3731	0.4003	0.3862	0.4120	

Measurement uncertainty of the color coordinates ± 0.003

Typical Electrical / Optical Characteristics Curves (25°C Ambient Temperature Unless Otherwise Noted)

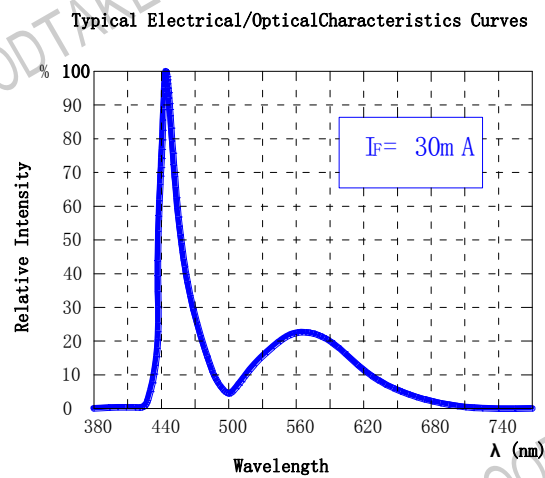
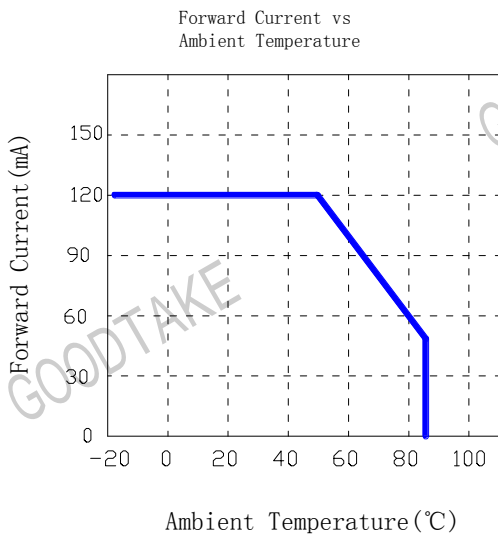
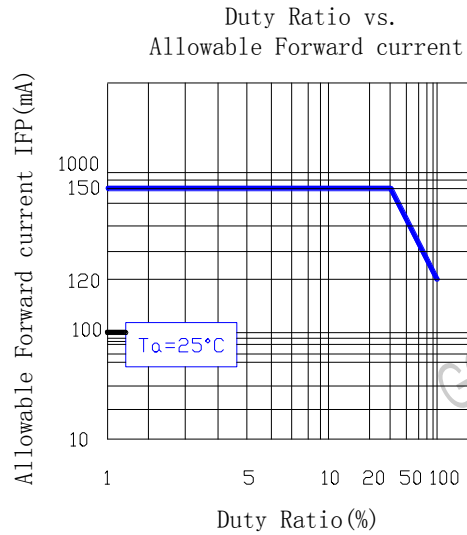
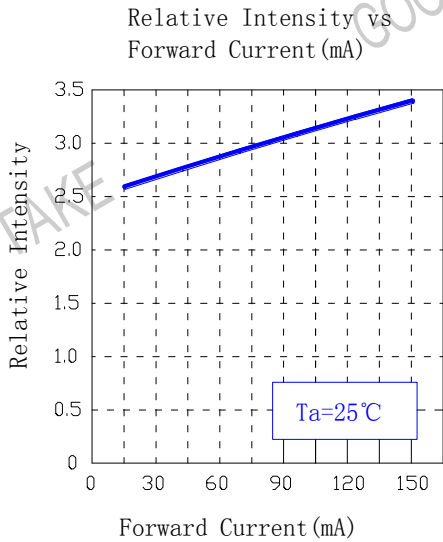
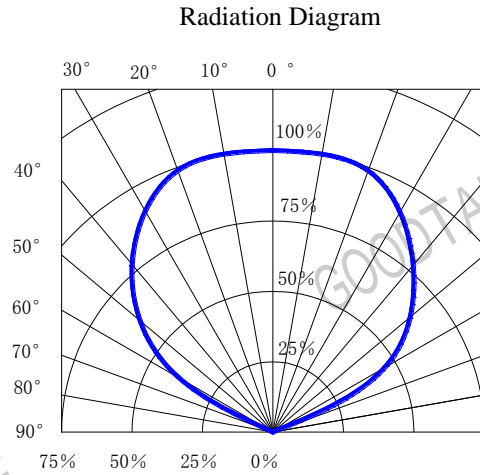
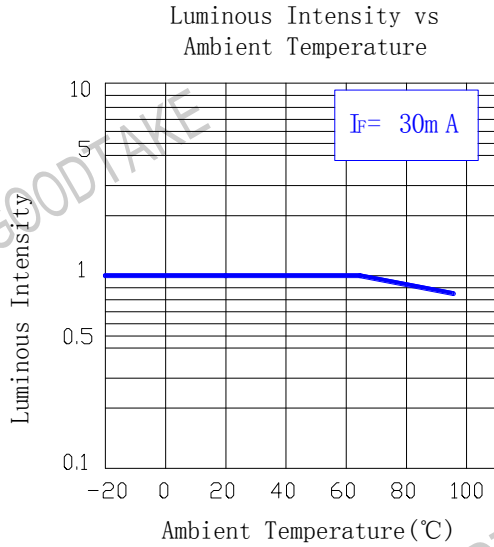

Test items and results of reliability

NO	Item	Test Conditions	Test Hours/Cycle	Sample Size	Ac/Re
1	Reflow	TEMP: 260±5°C Min. 5sec.	6 MIN.	22 PCS	0/1
2	Temperature Cycle	H: +100°C 15min ↓ 5 min L: -40°C 15min	300 CYCLES	22 PCS	0/1
3	Thermal Shock	H: +100°C 5min ↓ 10 sec L: -10°C 5min	300 CYCLES	22 PCS	0/1
4	High Temperature Storage	TEMP: 100°C	1000 HRS	22 PCS	0/1
5	Low Temperature Storage	TEMP: -55°C	1000 HRS	22 PCS	0/1
6	DC Operating Life	I _F = 120 mA / 25°C	1000 HRS	22 PCS	0/1
7	High Temperature / High Humidity	85°C / 85%RH	1000 HRS	22 PCS	0/1

Packaging Specifications

Feeding Direction

Dimensions of Reel (Unit: mm)

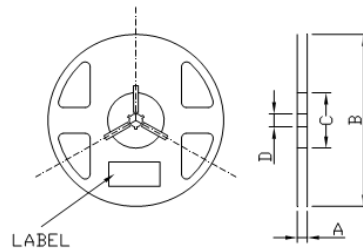
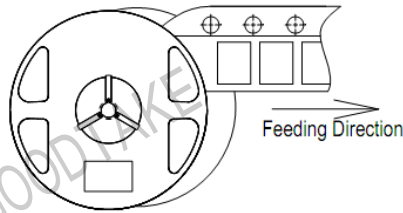

A	8.0 ± 0.1mm
B	178 ± 1mm
C	60 ± 1mm
D	13.0 ± 0.5mm

Dimensions of Tape (Unit: mm)

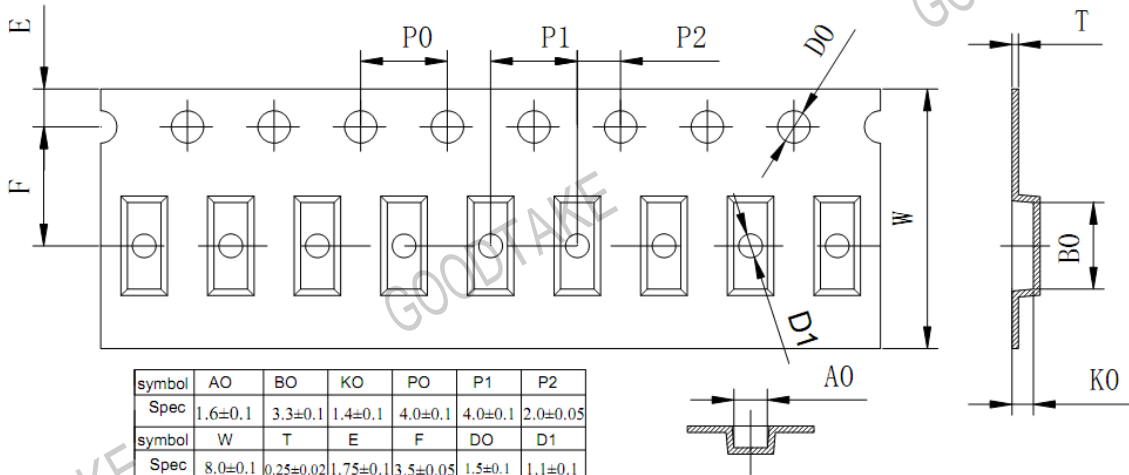

Arrangement of tape:

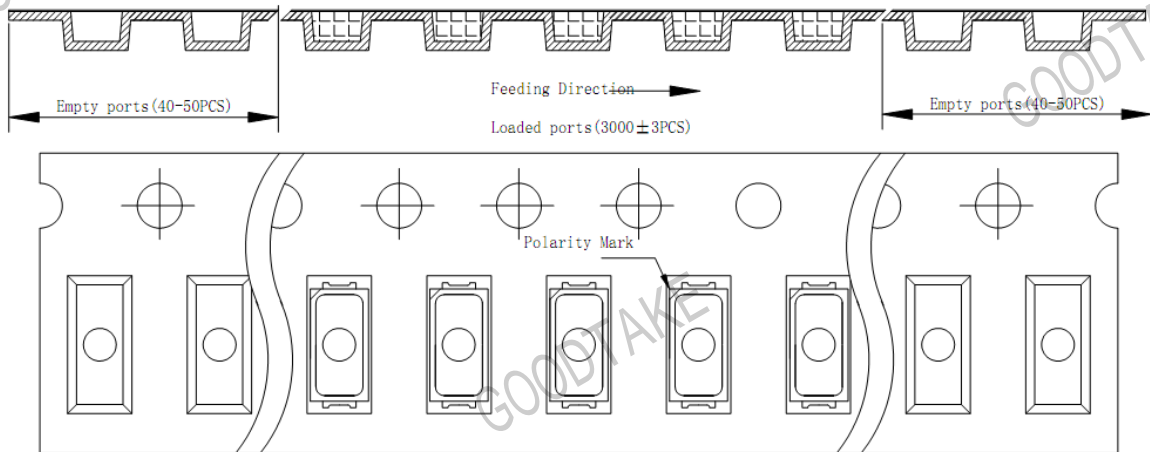

NOTES

1. Empty component pockets are sealed with top cover tape;
2. The maximum number of missing lamps is two;
3. The cathode is oriented towards the tape sprocket hole in accordance with ANSI/EIA RS-481 specifications.
4. 3,000 pcs/ Reel.

Packing Information

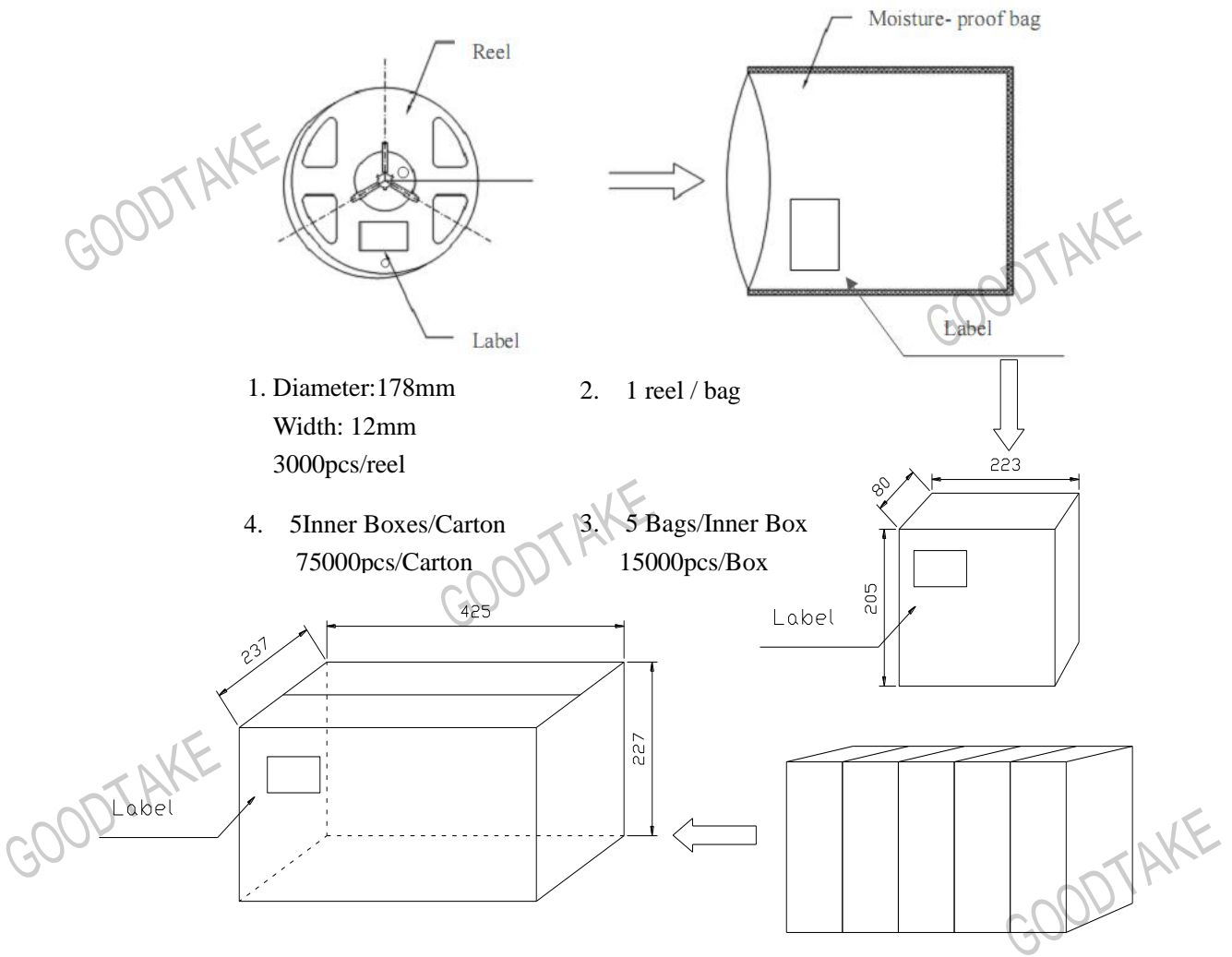

Soldering Condition

1. Pb-free solder temperature profile

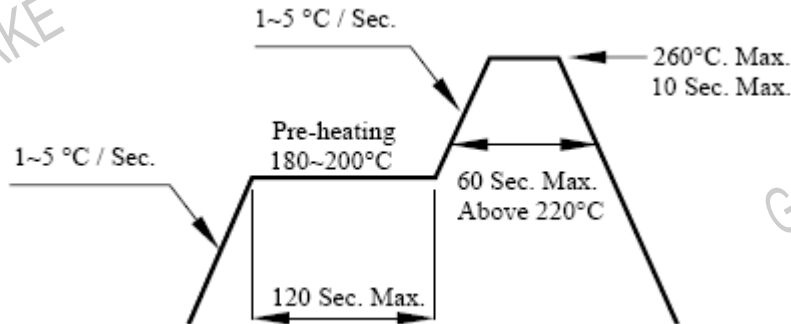

2. Reflow soldering should not be done more than two times.
3. When soldering, do not put stress on the LEDs during heating.
4. After soldering, do not warp the circuit board.

Soldering Iron

Each terminal is to go to the tip of soldering iron temperature less than 350°C for 3 seconds within once in less than the soldering iron capacity 25W. Leave two seconds and more intervals, and do soldering of each terminal. Be careful because the damage of the product is often started at the time of the hand solder.